

Electric Heaters

Fast and Efficient
Manufacturing

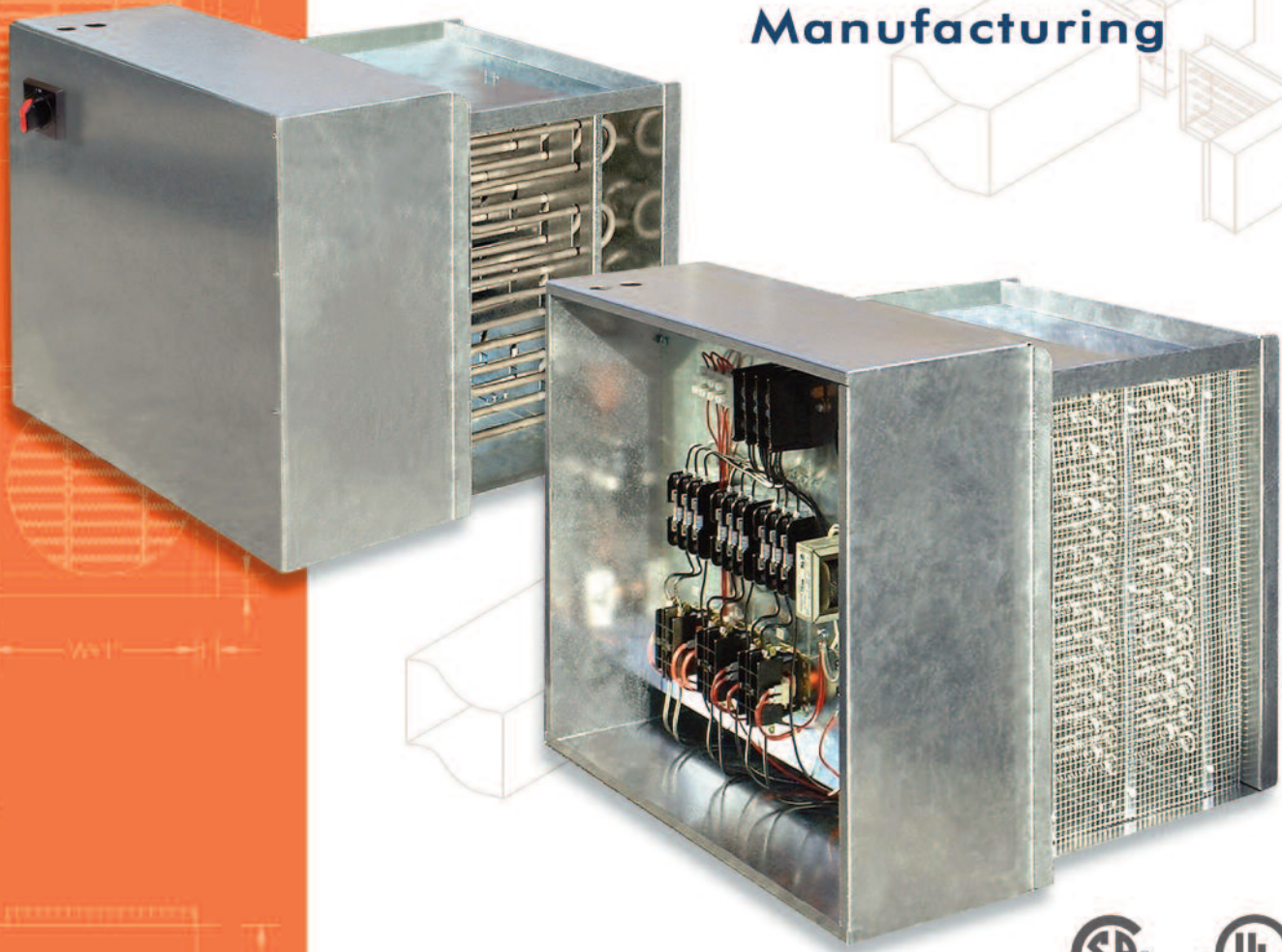

Easy to Select



neptronic®



Neptronic

Toll Free: 1 800 361-2308
 TEL: (514) 333-1433
 Fax:(514) 333-3163

Business hours: from Monday to Friday,
 8:00A.M. to 5:00P.M.
 (Eastern time)

E-Mail: contact@neptronic.com

- Introduction.....1
- Heater Selection Software.....2
- Manufacturing.....3
- Description of Components7
- Frame10
 - Slip-In Electric Heater - Type I.....10
 - Flanged Electric Heater - Type F10
 - Round Collar option11
 - Horizontal or Vertical Mounting11
 - Optional Accessories:.....11
- Control panel12
 - Standard Control Panel12
 - Control Panel Options12
 - Enclosure Types (control panels)13
- Special electric heaters14
- Materials & Dimensions.....15
- Heating Elements16
 - Open Coil Elements - Model C16
 - Standard Tubular Elements - Model T16
 - Finned Tubular Elements - Model F.....16
 - Selection Guide.....17
 - Static Pressure Loss17
- Selection and Installation Tips.....18
 - Calculation of Required Capacity18
 - Minimum Air Velocity18
 - Air Flow Conditions.....19
 - Electric Heater Current Calculation20
 - Voltage Selection.....20
- Electrical Construction.....22
 - Electric Control22
 - Pneumatic Control23
- Electrical Components26
- Neptronic Electronic Heater Controller- HEC.....27
- HEC Controller27
- Typical Wiring Diagrams.....28
- Legend.....30
- Sensors and Thermostats32
 - Duct Mount Temperature Sensor - STC8-13.....32
 - Wall Mount Temperature Sensor- STR1.....32
 - VAV Wall Mount Controller- TRO24-EXT133
 - VAV Wall Mount Controller- TRO540434
 - Wall Mount Thermostat- STS333
 - Wall Mount Controller for Make-Up Air- TMA5435
- Option Summary Sheet.....37
- Nomenclature38
- Specifications39
- Formulas and Conversions43



A Wide Range of HVAC Products

Founded in 1976, Neptonic is a private corporation that designs, manufactures and distributes products for the HVAC industry. Our product line includes intelligent controllers, electronic actuators, actuated valves, humidifiers and electric heaters.

Our products are designed and manufactured by over 250 dedicated employees in our 7,500 m² (80,000 ft²) state-of-the-art facility located in Montreal, Canada. Using a vertical integration model, our entire manufacturing chain is under one roof from software and hardware development, to SMT circuit board assembly, to sheet metal fabrication, to product testing ensuring that our products are engineered to last.



With our continued commitment to research and development, we provide innovative products and technologies for the ever evolving challenges of the HVAC industry. We are ISO 9001:2008 certified and committed to supplying reliable products and quality service around the world. Exporting over 85% of our sales, we have an exclusive distribution network around the globe that provides comprehensive solutions to our worldwide customers.

A Neptronic Innovation: Heater Selection Software

Neptronic is the first manufacturer of electric heaters to offer to its clients, the possibility to obtain specifications directly on our web site: www.neptronic.com.



Our selection software allows access to technical data and formulas to specify Neptronic heaters and much more.

Whether you are an engineer or a contractor, our software allows you to select the required electric heater by entering basic data (duct dimensions, airflow, power, voltage, number of stages, control signals, etc.) from a user friendly window. The selection software then calculates the optimum specifications for each electric heater.

The comprehensive heater specifications, as well as the approval list, may be edited or inserted in the project file.

Easy to Select

Duct Heater Approval Drawings

All 1 heaters selected

Date: 22/03/2016
 Project Number: 100020007
 Project Name: New Project
 Reference Number: Customer
 Engineer: Patrick Victor
 Submitted By: Neptronic Company

Item	Qty	Power	Heater	Control type	CFM	FPM	Electrical Data				Stages	Drawings	
							P (Watt)	U (V)	I (A)	Q (kVAr)			
1	1	12.00	DP C1004	4.00	8.50	24.00	8.00	1466	400	112.00	208-2133.31	24	M568R20007-A E146820007-A

Model Legend

- C Open Coil
- T Tubular
- F Flange
- L Lube
- H No Screen
- B Button
- R Right
- S Screen
- F Flange
- W No Screen
- L Lube
- S Screen
- A A
- B B
- C C
- D D
- E E
- F F
- G G
- H H
- I I
- J J
- K K
- L L
- M M
- N N
- O O
- P P
- Q Q
- R R
- S S
- T T
- U U
- V V
- W W
- X X
- Y Y
- Z Z

Components & Options Legend (Open Coil)

- AC Automatic thermal cabinet
- BC Control box with soft start
- CD Magnetic contactor
- DE Control type
- FG Disconnect switch
- HI Electronic safety sensors
- JK Full inrush protector
- LM Manual thermal cabinet
- NO Normal thermal cabinet
- PI Control Panel NEMA 1
- PS QS Customer

WARNING: Dimension of cables before starting a lot of work.

IMPORTANT: Check impedance with the manufacturer before starting a lot of work.

NOTE: All cables must be approved by client.

This quote is valid for a period of 30 days. F.O.B. Montreal, Quebec, Canada.

Customer: [Blank]
 Project: [Blank]
 Date: [Blank]

By: [Blank]
 Date: [Blank]
 Ref Price: [Blank]

You are in control of all your projects and will be able to assign your own reference numbers. Modifications are made directly from your computer.

To obtain a price, forward the selected list of heaters to one of our representatives for fast and efficient service.

The unique selection software allows data to be transferred automatically between the representatives and our manufacturing plant, eliminating errors that can arise during data transfer.

State-of-the-Art Technology



The Neptronic electric heater is manufactured using the most advanced technologies available:

- Total automation from design to production using integrated CAD/CAM systems not only assures maximum efficiency, but also prevents errors in the transfer of plans and specification data between the client, the R&D department and manufacturing personnel.
- The most advanced CNC technology for sheet metal fabrication is used in manufacturing the heaters.

All these factors were key in designing a complete line of electric heaters that are sturdy, easy to install and which include standard features that our competitors offer only as options, such as control panel doors with removable hinges.

Fast and Efficient Manufacturing

A Guarantee of Quality

Modern equipment allows us to respond in record time to your needs and to the most demanding specifications.

This infrastructure is supported and managed by our highly skilled specialists to whom quality workmanship is of utmost importance.





OVERVIEW & MECHANICAL CONSTRUCTION

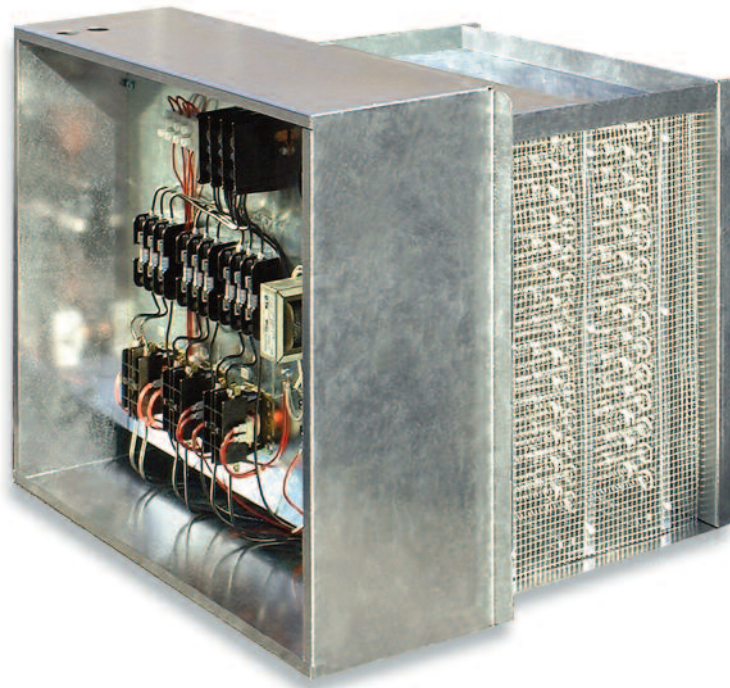

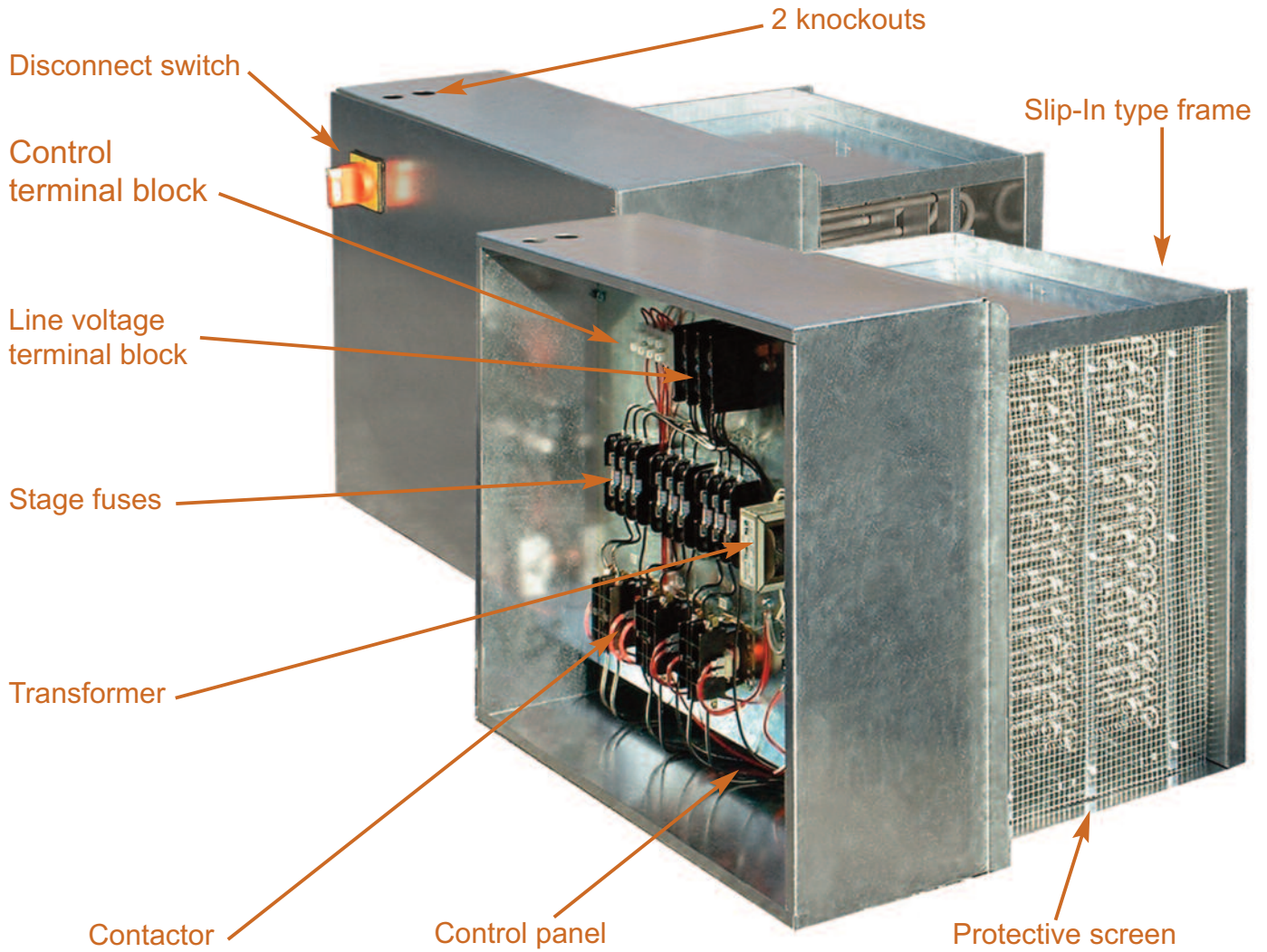

fig.2.1





Magnetic Contactor

Provides power to the individual stages of the heater.
Standard



Transformer

Supplies power to the control circuit. Supplied with a fuse.
Standard



Automatic Reset Thermal Cut-Out

An automatic reset, primary safety device. Removes power from elements if overheating occurs.
Standard



Airflow Switch

Safety component used to prevent a heater from operating if there is no airflow.
Standard for ON/OFF heaters



Solid State Relay (SSR)

Proportionally controls the amount of power transmitted to the heating elements. Allows quiet operation and is exceptionally reliable.
Standard for proportional heaters



Manual Reset Thermal Cut-Out

A secondary safety device which removes power to the elements if overheating occurs.
Standard when required by code, otherwise optional

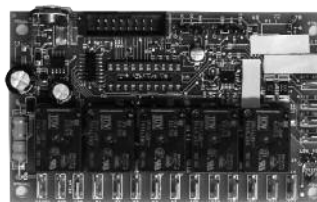

Neptronic HEC Electronic Controller

A unique control and safety component. Controls and optimizes the power transmitted to the heating elements according to the duct temperature and air flow.
Standard for proportional heaters.



Pneumatic Electric Switch

Converts a pneumatic ON/OFF signal to an electric signal.
Standard for heaters with pneumatic ON/OFF signal

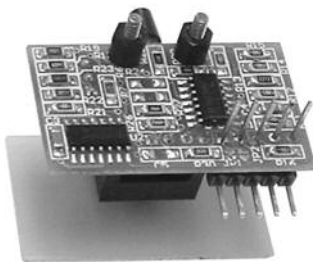

Pneumatic Electric Control

Converts a proportional pneumatic control signal to a proportional electric signal.
Standard for proportional units with pneumatic signal



Disconnect Switch

Cuts the power supply to the heater in order to safely perform installation and maintenance tasks.
Standard when required by code, otherwise optional



Fuses

Protect the total load and/or the individual heater stages.
Standard when required by code, otherwise optional



Mercury Contactor

Provides power to the individual stages of the heater. Allows quiet, reliable operation.
Optional



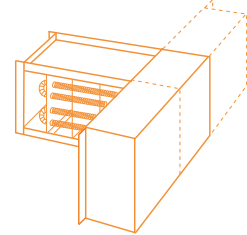
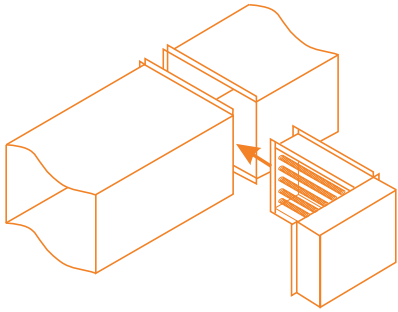

MECHANICAL CONSTRUCTION

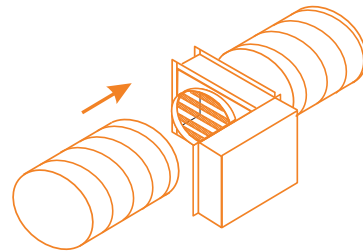
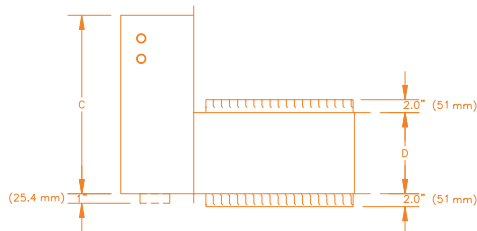
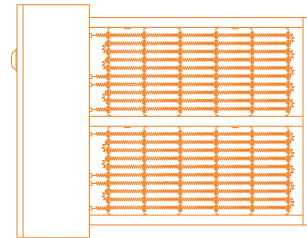
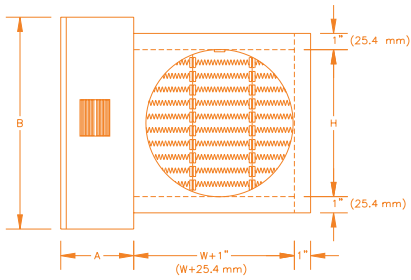

Slip-In Electric Heater - Type I

The slip-in type electric heaters are designed so that the entire frame can be inserted into the duct.

Advantages of slip-in electric heaters:

A system using a slip-in heater permits the installation of the entire ventilation duct system before the heaters become available. Retrofits are much simpler, smaller dimension slip-in heaters require no extra supports.

To order a Neptronic slip-in heater, specify the dimensions of the duct and the selection software will automatically calculate the optimum heater dimensions.

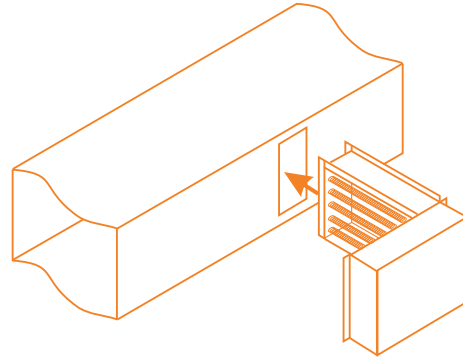

fig.2.2

Installation:

Allow for a proper sized opening on one side of the duct, see fig. 2.2, as well as installation clearances to avoid any obstructions around the duct. The Neptronic slip-in heater has a standard 1" (25.4mm) flange on each side of the control box and can be attached directly to the duct with sheet metal screws.

Flanged Electric Heater - Type F

Flanged heaters are designed so that the heater is an integral part of the duct work. The heater frame is attached to matching duct flanges, see fig. 2.3. Standard 1" (25.4mm) on the heater frame are used to attach it to the duct.

Flanged heater dimensions match the dimensions of the duct. Custom flanges can be provided for heaters requiring extra support or for large heaters.

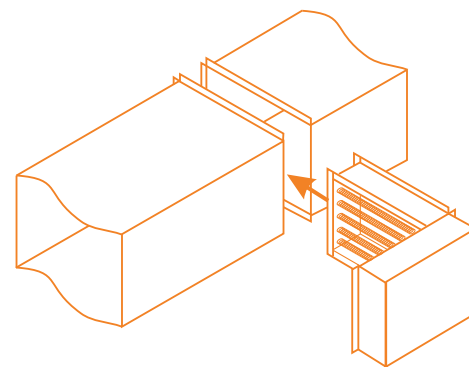

fig.2.3

Installation:

The Neptronic electric heater comes with 1" (25.4mm) standard flanges installed around the frame and on each side of the control box. It can be attached directly onto the duct with sheet metal screws.

Note: Round collar option available with flanged electric heater type F

Round Collar option

Round collar electric heaters are available for installation on round duct systems with a standard diameter of 6" to 24" (152mm to 609mm). They are provided with one male and one female adapter for ease of installation.

Installation:

The Neptronic round collar electric heater comes with a 1" (25.4mm) extension on each side of the frame. The heater is attached directly onto the duct using sheet metal screws.

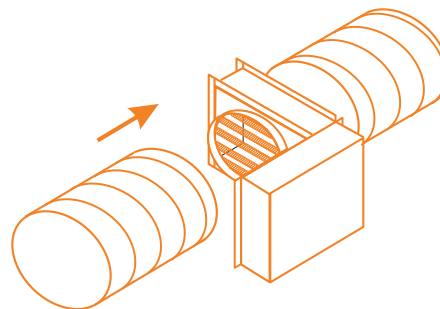

fig.2.4

Zero Clearance Construction

All Neptronic heaters are designed and approved for zero clearance to combustible material. Zero clearance construction means that there is no restriction on the distance between combustible materials and the section of the duct housing the heater, or the heater itself. The control panel must be accessible for servicing.

Horizontal or Vertical Mounting

Neptronic electric heaters are designed to be installed in either horizontal or vertical ducts. Please specify the airflow direction with an H for horizontal and a V for vertical to ensure correct orientation of the components in the control panel.

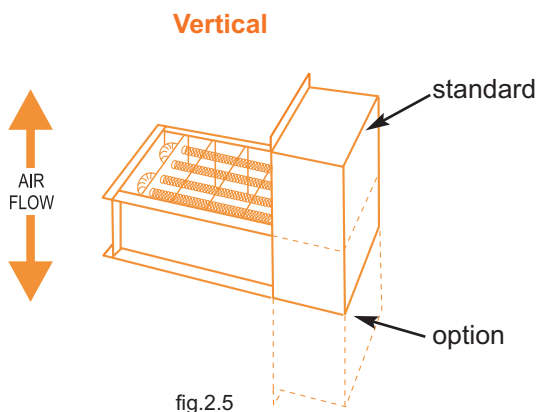

fig.2.5

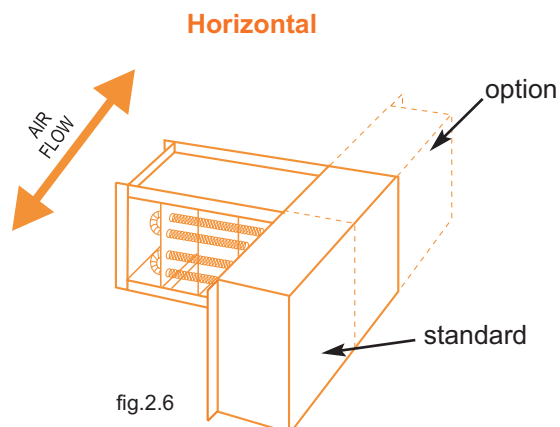

fig.2.6

Optional Accessories:

Protective Screens:

Optional protective screens are available to prevent accidental contact with the heating elements.

Option 10 or 01: Protective screens on one side only - 10 left of the control panel, 01 right of the control panel.

Option 11: Protective screens on both sides of the heater.

Standard Control Panel

The control panel attached to the heater exceeds the frame dimensions by 1" (25.4mm) on the top and bottom. If installation conditions do not allow for this standard extension, a control panel with dimensions equal to the heater frame can be provided.

The standard extension of the control panel is to the left. If installation conditions do not permit the extension to the left, you must specify the direction for the extension of the control panel.

Control Panel Options

Bottom Control Panel

A bottom control panel can be supplied, when required for easy installation and maintenance.

This option is available for all heaters (Slip-in, flanged and round collar) of small dimensions.

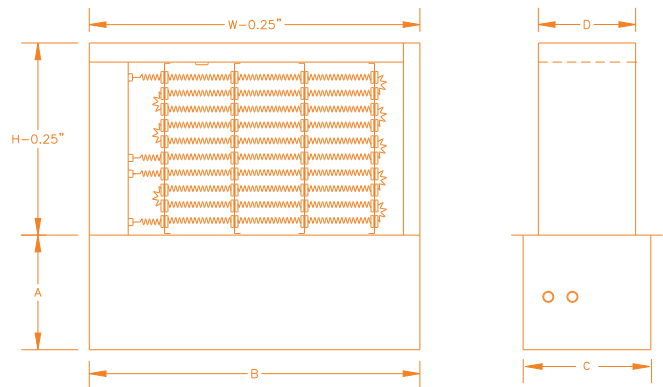

fig.2.7

Insulated Control Panel

An insulated control panel is recommended for high duct temperatures.

Insulation material, 1" (25.4mm) thick is installed between the panel and the hot area to prevent condensation on electrical components.

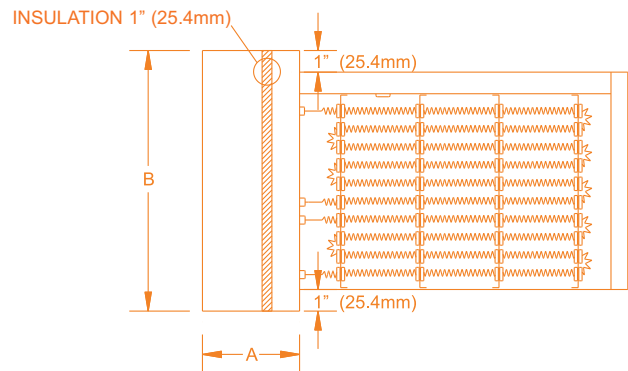

fig.2.8

Remote Control Panel

In certain cases it may be more convenient to install the control panel remotely from the heater or in a separate room. A remote control panel can be supplied upon request.

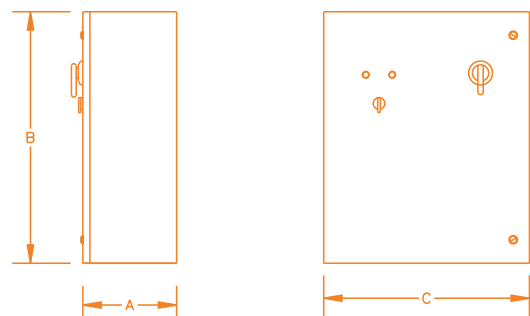

fig.2.9

Enclosure Types (control panels)

Nema 1

(IP 10)

Protected against access

Enclosures constructed for indoor use to provide a degree of protection to personnel against incidental contact with the enclosed equipment and to provide a degree of protection against falling dirt.

This enclosure type is standard on Neptronic electric heaters.

Nema 12

(IP 52)

Dust-protected

Enclosures constructed (without knockouts) for indoor use to provide a degree of protection to personnel against incidental contact with the enclosed equipment; to provide a degree of protection against falling dirt; against circulating dust, lint, fibers, as well as water spray and light splashing of liquids, water infiltration, oil or non corrosive liquid refrigerant.

Nema 4

(IP 56)

Protected against
splashing water

Enclosures constructed for either indoor or outdoor use to provide a degree of protection to personnel against incidental contact with the enclosed equipment; to provide a degree of protection against falling dirt, rain, sleet, snow, windblown dust, splashing water, and hose-directed water; and that will be undamaged by the external formation of ice on the enclosure.

Nema 4X

(IP 65)

Protected against corrosion

Enclosures constructed for either indoor or outdoor use to provide a degree of protection to personnel against incidental contact with the enclosed equipment; to provide a degree of protection against falling dirt, rain, sleet, snow, windblown dust, splashing water, and hose-directed water, and corrosion; and that will be undamaged by the external formation of ice on the enclosure.

The control panel and/or the electric heater are constructed in stainless steel for this option.

Special Electric Heaters

Heater with Cold Section

In special cases a cold section in the air duct is required. For example, when air flow has been altered near the area where the heater is located. In this case the heater will be built in order to adapt to this constraint. Specify the location and dimensions of the cold section(s) using the control panel as your reference point. (see fig. 2.10)

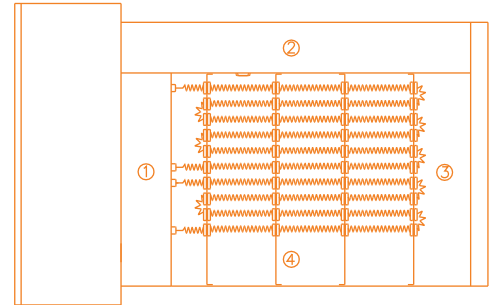

- ① COLD SECTION ON THE SIDE OF CONTROL PANEL
- ② COLD SECTION ON TOP
- ③ COLD SECTION OPPOSITE THE CONTROL PANEL
- ④ COLD SECTION ON THE BOTTOM

fig.2.10

Large Heaters

Heaters whose dimensions exceed 40" (1.0m), will be reinforced by Neptronic to assure proper rigidity. Multiple thermal cut-outs will be installed and evenly distributed to obtain the same level of safety as for a standard size heater. In some cases, the large heater will be constructed in two sections to simplify the installation.

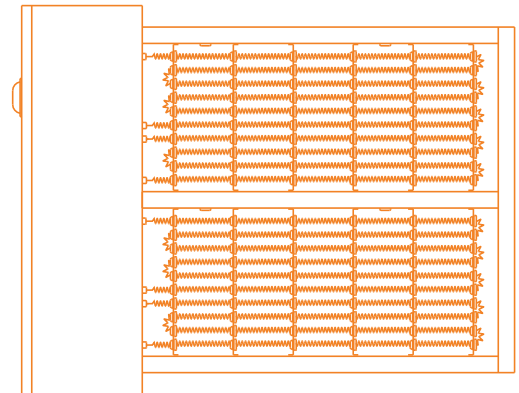

fig.2.11

Process Heaters

Special application heaters for baking, drying or other processes up to a temperature of 1,200°F (648°C) and 1,000kW can be designed and built to Neptronic's proven standards.

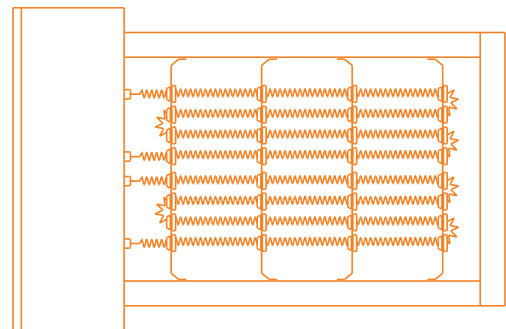

fig.2.12

Materials

Nepronic heaters are manufactured with the appropriate galvanized steel gauge to assure rigidity and corrosion protection.

Nepronic heaters can be constructed with 304 stainless steel for special applications.

Typical Dimensions

Type I (slip-in)

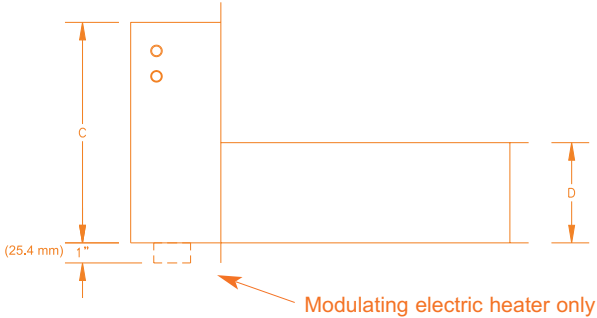
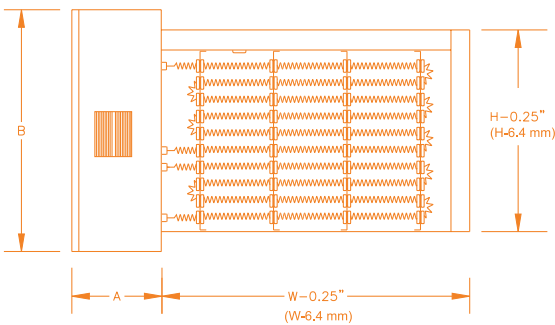

fig.2.13

Type F (flanged)

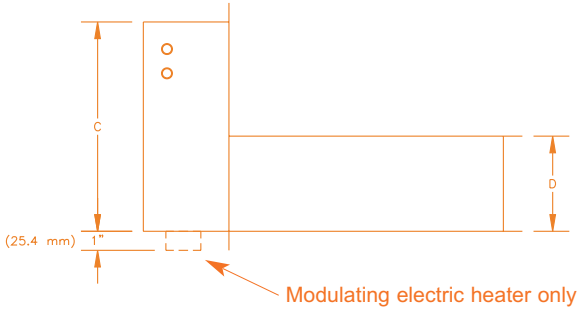
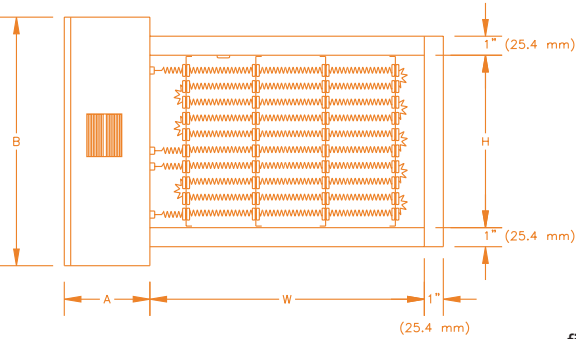

fig.2.14

Round collar option with type F

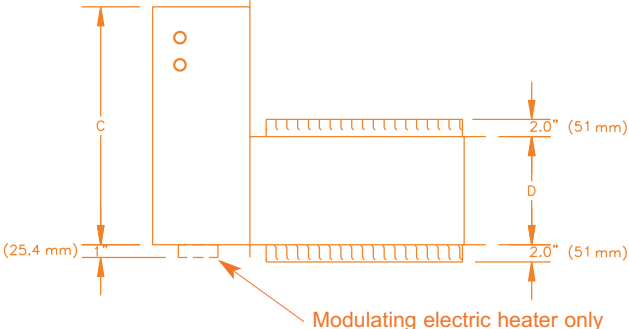
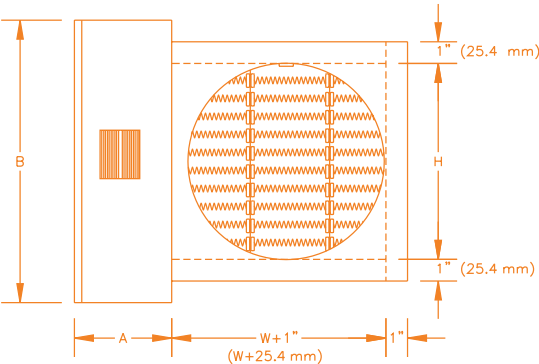

fig.2.15

W: Width of air duct H: Height of air duct

Open Coil Elements - Model C

Standard open coil elements are NiCr 60 (grade C). They are composed of 60% Nickel, 16% Chrome and the balance is Iron. The maximum operating temperature is 1,850°F (1,000°C).

For applications in a humid environment, we recommend the optional NiCr 80 (grade A) elements. They are composed of 80% Nickel and 20 % Chrome (does not contain iron). This will allow a maximum operating temperature of 2,100° F (1,150°C) and installation where condensation may be present in the air duct.

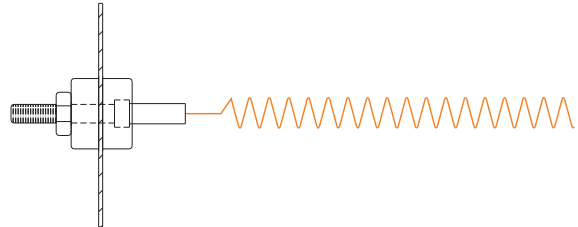

fig.2.16



fig.2.17

Finned Tubular Elements - Model F

Finned tubular elements are made of Incoloy 800 (Nickel alloy) tube with a diameter of 3/8" (9.5mm) containing a heating coil in magnesium oxide powder. The tube is equipped with steel fins and available with stainless steel fins as an option to allow for more efficient heat dissipation.

Attachments are made with two terminals (10-32). The U or W shape of the tubular elements is determined by the heater dimensions.

Option: Fins can be supplied in stainless steel upon request.

Standard Tubular Elements - Model T

Tubular elements are made of Incoloy 800 (Nickel alloy) tube with a diameter of 3/8" (9.5mm) containing a heating coil in magnesium oxide powder. Connections are made with two terminals (10-32).

The U or W shape of the tubular elements is determined by the heater dimensions.

Option: Tubular element can be made in stainless steel upon request



fig.2.18

Selection Guide

Element Types	Advantages	Disadvantages
Open Coil	<ul style="list-style-type: none"> • Excellent heat dissipation • Minimal pressure drop • Fast response time • More kilowatts per sq.ft. • Quick delivery 	<ul style="list-style-type: none"> • Elements in direct contact with air • Cannot be installed in humid environments • Cannot be installed in dusty environments
Standard Tubular	<ul style="list-style-type: none"> • Less sensitive to humidity and dust • Suited for demanding environments • Excellent mechanical resistance • Heating element not in direct contact with air 	<ul style="list-style-type: none"> • Increase in pressure drop • Slower response time • Less heat dissipation • Less kilowatt per sq.ft. • Longer delivery
Finned Tubular	<ul style="list-style-type: none"> • Good heat dissipation • Less sensitive to humidity and dust • Suited for demanding environments • Excellent mechanical resistance • Heating element not in direct contact with air 	<ul style="list-style-type: none"> • Increase in pressure drop • Slower response time • Less kilowatt per sq.ft. • Longer delivery

table 2.1

Static Pressure Loss

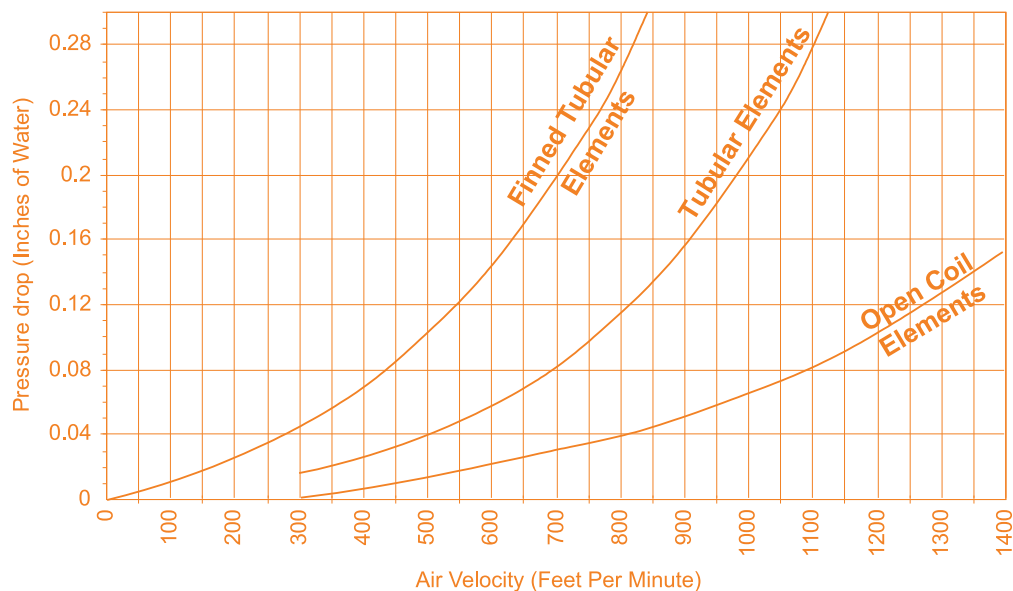

fig.2.19

Calculation of Required Capacity

Power or electric heater capacity

Imperial

$$kW = \frac{CFM \times (T^{\circ}2 - T^{\circ}1) \times 1.08}{3413}$$

kW : Power in kW
CFM : Air volume in Cubic Feet per Minute
T[°]2 : Temperature of air leaving heater in °F
T[°]1 : Temperature of air entering heater in °F

Metric

$$P = \frac{Q \times (T^{\circ}2 - T^{\circ}1) \times 1,21}{3600}$$

P : Power in kW
Q : Air volume in m³/hour
T[°]2 : Temperature of air leaving heater
T[°]1 : Temperature of air entering heater

Minimum Air Velocity

Open Coil Elements

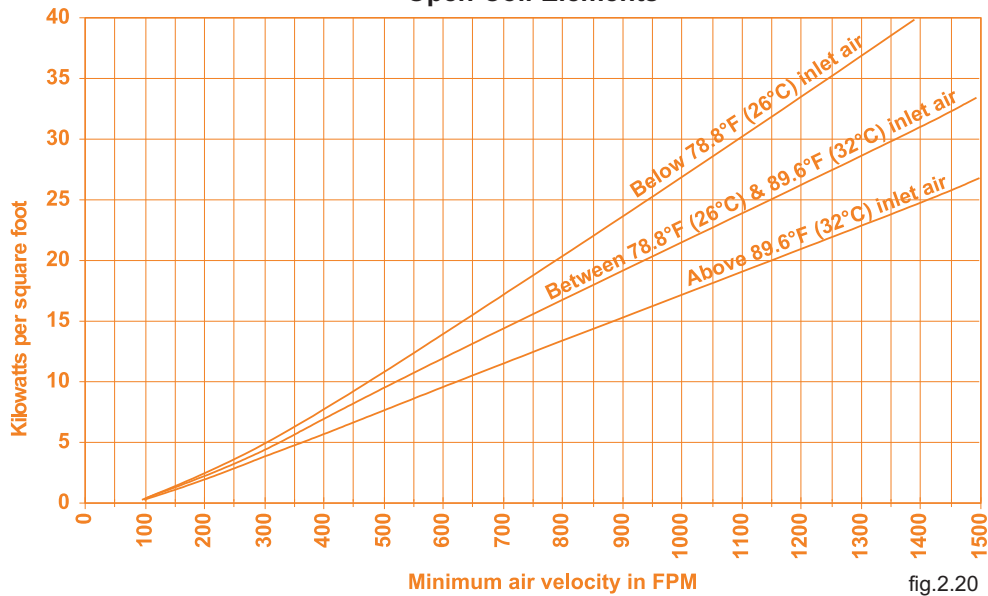

fig.2.20

Tubular Elements

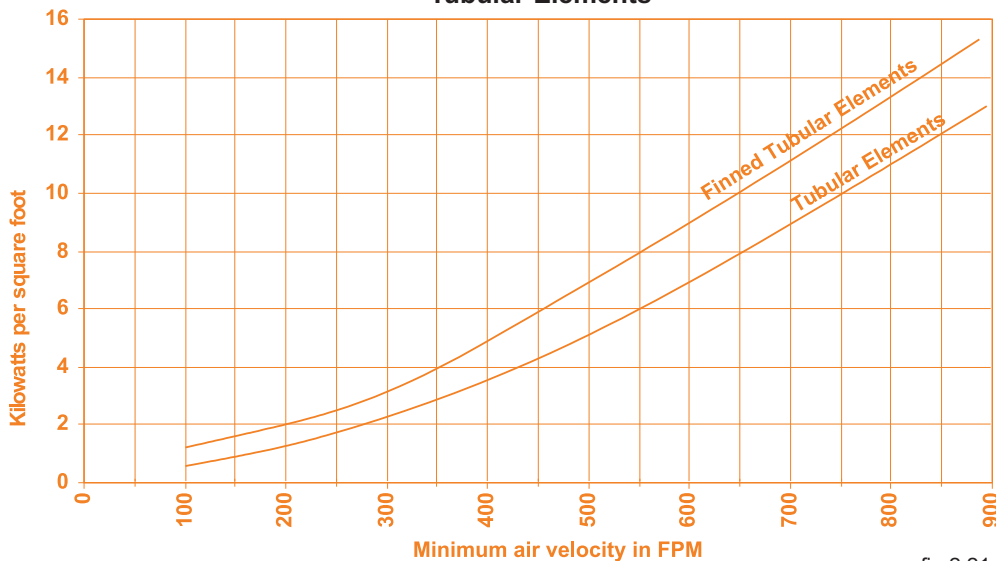

fig.2.21

Air Flow Conditions

Basic rules:

- Allow a minimum distance of 3 times the duct diameter between any obstacle or elbow and the electric heater.
- Airflow must be evenly distributed across the duct.

If these basic rules are not respected overheating may result.

- ⚠ If the electric heater is located too close to a filter or diffuser, 3 overheating areas may occur (fig. 2.22).

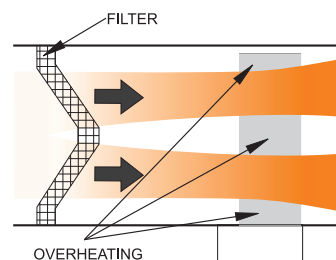

fig.2.22

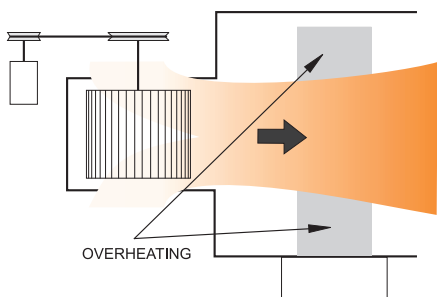

fig.2.23

- ⚠ If the electric heater is located too close to a fan, 2 overheating areas may occur (fig.2.23).

- ⚠ If the electric heater is located too close to an elbow, 1 overheating area may occur (fig. 2.24).

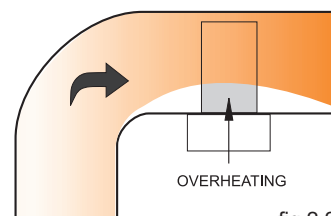

fig.2.24

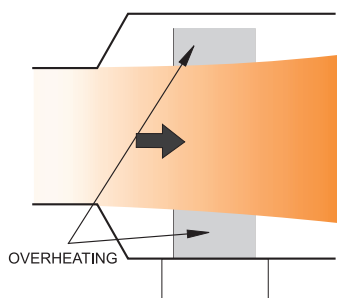

fig.2.25

- ⚠ If the electric heater is located too close to a transition, 2 overheating areas at the edges of the heater may occur (fig 2.25).

If one of these overheating conditions exists, the life expectancy of the heating elements will be affected. We advise that the basic rules stated above be followed. If these conditions cannot be avoided, Neptronic can provide cold sections in the appropriate areas of the electric heater (see the section on special electric heaters fig.2.10).

Electric Heater Current Calculation

Single phase

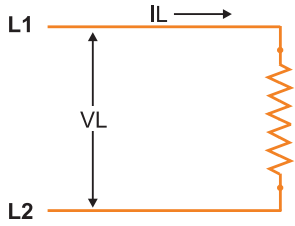

fig.2.26

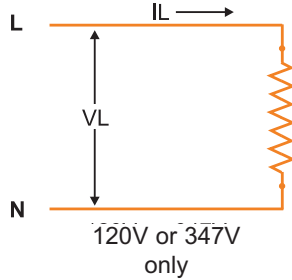

fig.2.27

IE = Current through element in Amps
 VE = Element Voltage in Volts
 IL = Line Current in Amps
 VL = Line Voltage in Volts
 P = Power in Watts

Three phases

Delta connection

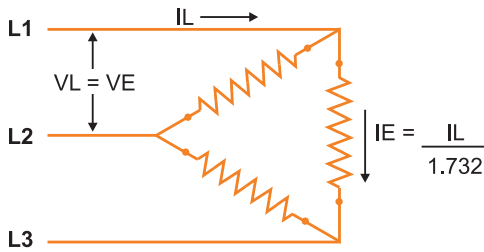

fig.2.28

Wye connection

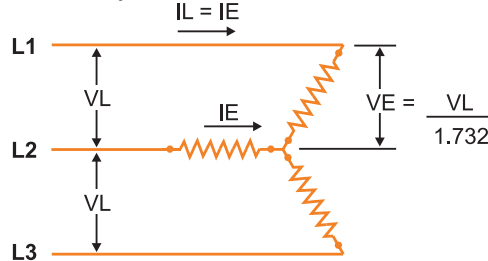

fig.2.29

Voltage Selection

In order to avoid overheating due to inappropriate voltage, we recommend selecting Neptronic standard voltages as listed below:

Single phase

Common Voltages	110V	208V	220V	230V	277V	318V	380V	416V	440V	550V
	115V			240V		332V			460V	575V
	120V			347V		480V			600V	
Neptronic Standard Voltages	120V	208V	220V	240V	277V	347V	380V	416V	480V	600V

table 2.2

Three phases

Common Voltages	208V	230V	380V	400V	440V	550V
		240V		416V	460V	575V
					480V	600V
Neptronic Standard Voltages	208V	240V	380V	416V	480V	600V

table 2.3

Please carefully select the supply voltage of the electric heater. Over estimation of the supply voltage may result in inadequate performance of the electric heater due to under capacity. Any under-estimation of the supply voltage may cause an increase in current and power and by consequence safety issues. Please consult your Neptronic representative for any non-standard voltage.

ELECTRICAL CONSTRUCTION

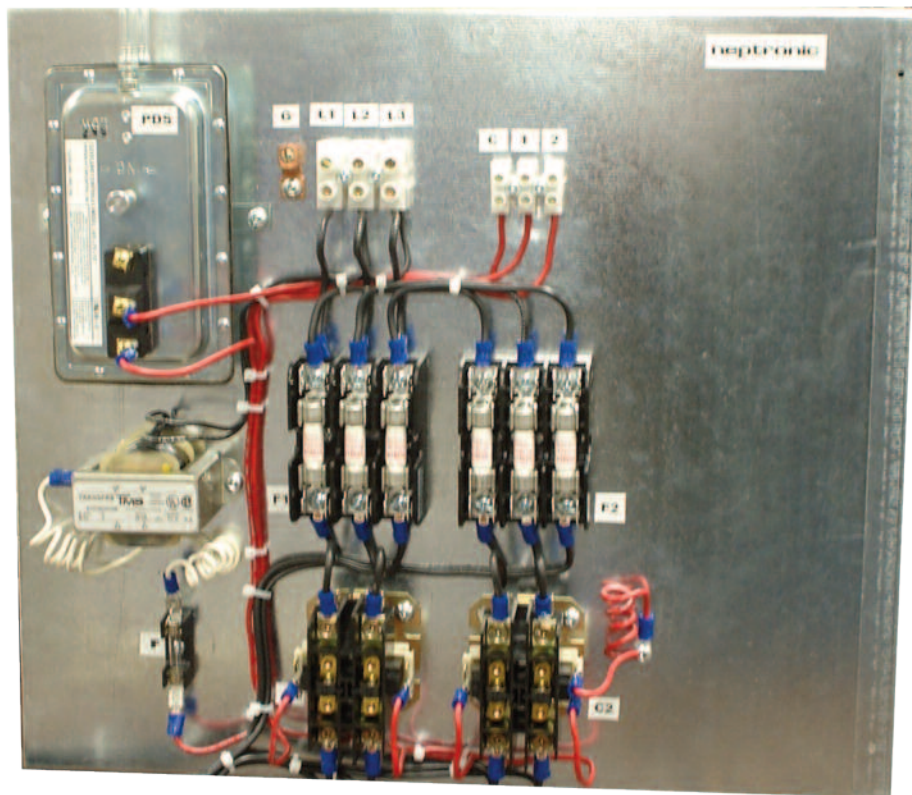

Electric Control

ON/OFF Control

The control panel of an ON/OFF electric heater includes the following components:

- Transformer and control fuse
- Automatic reset thermal cutout
- Manual reset thermal cutout when required by code, otherwise optional
- Airflow switch
- Contactor(s)
- Fuses when required by code, otherwise optional
- Disconnect switch when required by code, otherwise optional

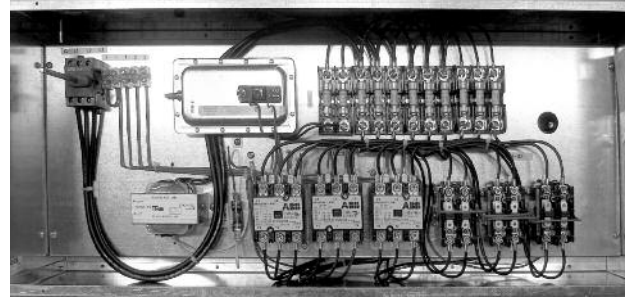

fig.3.1

Operation:

A thermostat dry contact activates each stage of the electric heater.

Besides wiring of the power supply, you must connect the appropriate wires to the thermostat (see wiring diagram figure 3.18).

Proportional Control (Modulating)

The control panel of a proportional electric heater includes the following components:

- Transformer and control fuse
- Automatic reset thermal cutout
- Manual reset thermal cutout when required by code, otherwise optional
- Neptronic HEC controller
- Contactor(s)
- Solid state relay(s) (SSR)
- Fuses when required by code, otherwise optional
- Disconnect switch when required by code, otherwise optional

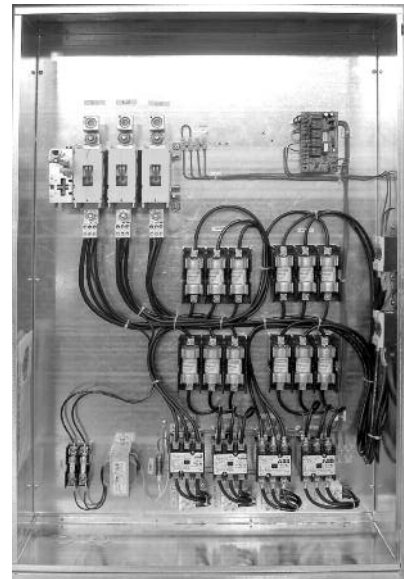

fig.3.2

Operation:

An electric signal from a proportional thermostat is transmitted to the HEC controller. The HEC activates the proportional stage of the electric heater. The other stages are generally ON/OFF and are controlled by the HEC controller.

Besides wiring of the power supply, you must connect the appropriate wires to the thermostat (see wiring diagram figure 3.19).

Pneumatic Control

ON/OFF Control

The control panel of an ON/OFF electric heater with pneumatic input includes the following components:

- Transformer and control fuse
- Automatic reset thermal cutout
- Manual reset thermal cutout when required by code, otherwise optional
- Airflow switch
- Pneumatic electric switch/proportional
- Contactor(s)
- Fuses when required by code, otherwise optional
- Disconnect switch when required by code, otherwise optional

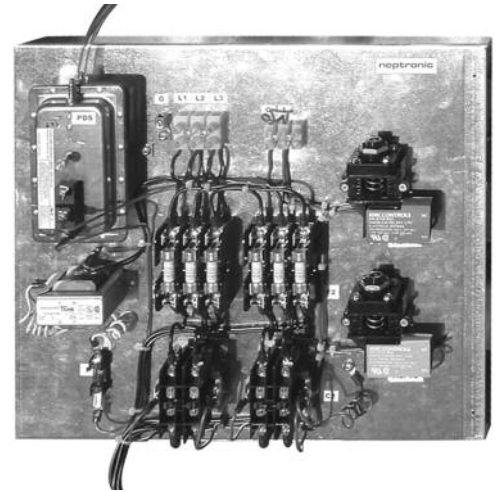

fig.3.3

Operation:

A pneumatic signal from a pneumatic thermostat activates the different stages of the electric heater.

Besides wiring of the power supply, you must connect a 1/4" (6mm) diameter, pneumatic signal tube onto the pneumatic electric switch (see wiring diagram figure 3.20).

Proportional Control (Modulating)

The control panel of a pneumatic proportional electric heater includes the following components:

- Transformer and load fuse
- Automatic reset thermal cutout
- Manual reset thermal cutout when required by code, otherwise optional
- Neptronic HEC controller
- Pneumatic electric controller
- Contactor(s)
- Solid state relay(s)
- Fuses when required by code, otherwise optional
- Disconnect switch when required by code, otherwise optional

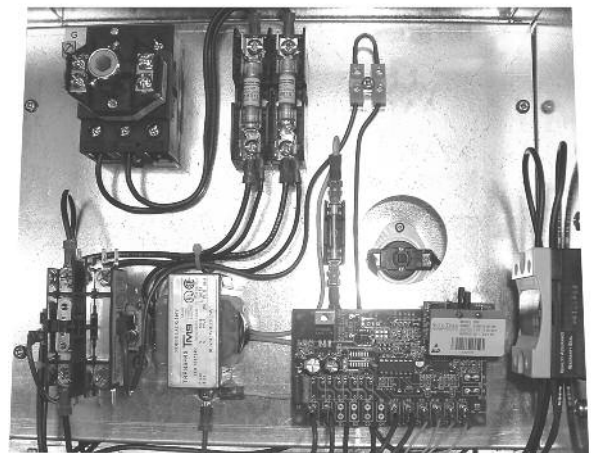

fig.3.4

Operation:

A proportional signal from a pneumatic thermostat is transmitted to the HEC controller. The HEC activates the proportional stage of the electric heater. The other stages are generally ON/OFF and are controlled by the HEC controller.

Besides wiring of the power supply, you must connect a 1/4" (6mm) diameter, pneumatic signal tube onto the pneumatic electric module (see wiring diagram figure 3.21).

Magnetic Contactor - code: CA

Magnetic Contactors are the Nepronic standard. They are reliable and field proven. They have been tested for a minimum of 250,000 operations.

Features:

- Coil Voltage: 24 or 120VAC
- Resistive Load from 25 to 50A at 600 VAC 50/60Hz
- Number of Poles: 1, 2, or 3



fig.3.5

Transformer (supplied with a control fuse) - code: TR

A transformer is standard on Nepronic electric heaters. The transformer supplies power to the control circuit. If you prefer that the control power be supplied by others, you must specify this with your order.

Features:

- Primary Voltage: same as that of electric heater
- Secondary Voltage: 24 or 120 VAC from 25 to 250VA
- Insulation: Class B



fig.3.6

Automatic Reset Thermal Cutout - code: AC

Standard for all Nepronic electric heaters. If overheating occurs, the automatic reset will remove power from the elements.

Features:

- Maximum Voltage and Current: 240VAC, 25A
- Cut-off Temperature:
 - Open coil elements: 110°F (43°C)
 - Tubular elements: 167°F (75°C)



fig.3.7

Airflow Switch - codes: PDN or PDA

A non-adjustable airflow switch (PDN) is standard for all ON/OFF Nepronic heaters. Prevents heater from operating if there is no airflow.

Features:

- Triggering Pressure: 0.03+/-0.02" w.c. (0.762+/-0.508mm w.g.) - adjustable optional (PDA)
- Maximum Pressure: 0.5psi (3.5kPa)
- Maximum Voltage and Current: 227V, 15A
- Tube Connections: 2 nozzles (6.35mm)
- Accessories: supplied with 3' (914mm) pitot tube to be installed in the duct.

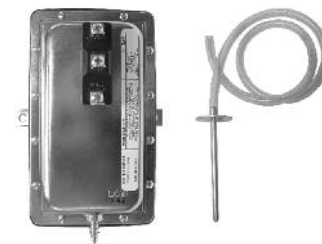

fig.3.8

Solid State Relay - code: SSR

Standard for proportional Nepronic heaters. Proportionally controls the amount of power transmitted to the heating element.

Features:

- Maximum Voltage: 600V
- Current: 50A, 100A or 125A
- Zero voltage crossing detection and switching



fig.3.9

Manual Reset Thermal Cutout -code: MC

Standard when required by code, otherwise optional.
Optional for all other electric heaters. If overheating occurs, the device must be manually reset.

Features:

Maximum Voltage and Current: 240V, 25A
Cut-off temperature adapted to:

- Open coil elements
- Tubular elements



fig.3.10

Pneumatic Electric Switch (ON/OFF) - code: PSO or PSC

Standard for heaters with pneumatic ON/OFF signal. Transmits the pneumatic signal to the electric circuit.

Features:

Pneumatic Signal: from 2 to 20psi (14 to 138kPa)
Maximum Pressure: 30psi (207kPa)
Maximum Voltage and Current: 277V, 25A
Pneumatic Connection: 1, 3/16" (5mm) nozzle for 1/4" (6mm) O.D. polyethylene tube
Normally Open (PSO) or Normally Closed (PSC)



fig.3.11

Pneumatic Electric Controller - code: PCD or PCR

Standard for modulating electric heaters with proportional pneumatic control signal.
Transmits proportional pneumatic control signal to the control circuit.

Features:

Pneumatic Signal: 0 to 15psi (0 to 103 kPa)
Direct (PCD) or Reverse (PCR) Acting
Output Signal: 0 to 10VDC
Supply Voltage: 12 or 24VAC
Pneumatic connection: 2 3/16" (5mm) nozzles for 1/4" (6mm) O.D. polyethylene tube



fig.3.12

Pilot Lights - codes: LP, LH, LN, LS or LO

Pilot lights are optional for all heaters. Pilot lights can indicate any of the following:

- Line Power ON (LP)
- Electric heater ON/OFF (LH)
- No airflow (LN)
- Stage ON (LS)
- Overheat (LO)

Pilot lights are installed on the front door of the control panel.

Features:

Voltage and Amperage: 24V, 0.073A or 120V, 0.025A
Color: Red or Green depending on application.



fig.3.13

Disconnect Switch - codes: DS or TS

A disconnect (DS) with door interlock or a toggle switch (TS) is optional (except when required by code). Cuts the power supply to the heater in order to safely perform installation and maintenance tasks.

The disconnect switch with door interlock (DS) prevents the control panel from being opened if the heater is powered. It is installed on the door of the control panel.

Features:

Number of Poles: 3
Maximum Voltage and Current: 600V, 800A



Disconnect Switch (DS)

fig.3.14

Fuses - code: SF or LF

Fuses are optional, except when required by code. They can be installed either on the supply line (LF) and/or on the individual heater stages (SF).

They protect the total load if overheating or a short circuit occurs. Characteristics depend on current flow.

Features:

Maximum Voltage: 600VAC
Current: from 1 to 600A
Type: HRC form 1 (fast acting)



fig.3.15

Mercury Contactor - code: CM

For special applications where quiet operation is required, magnetic Contactor can be replaced with optional mercury Contactor. Mercury Contactor have been tested for a minimum of 5,000,000 operations.

Features:

Coil Voltage: 24 or 120VAC
Resistive Load: 35A at 600VAC, 50/60Hz
Number of Poles: 1



fig.3.16

Silent Relay- code: CS

As an alternative to mercury contactor, silent relay can be supplied in option. These relays are for special quiet operations.

Features:

Coil Voltage: 24VAC
Resistive Load: - 26.0A at 120, 208, 240, 277VAC ; 60 Hz
- 13.6A at 480VAC ; 60 Hz
- 10.4A at 600VAC ; 60 Hz

Number of Poles: 2



fig.3.17

Auxiliary Switches - code: AUX

Auxiliary switch can be installed in option when the 3 pole standard magnetic contactor has been selected. When you need a remote dry contact with quick connect terminals. (maximum 2 per contactor)

Features:

Number of Poles: 2 (1 N.O. & 1 N.C.)
Contact Rating: 10A at 600VAC

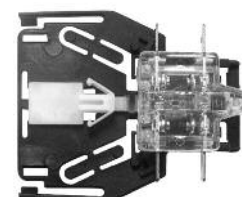

fig.3.18

Neptronic Electronic Heater Controller- HEC

The Neptronic HEC is a universal controller. It accepts any input signal used in the industry and converts it to a modulating or ON/OFF control signal to the solid state relay(s) and/or the contactor(s).

This controller assures an extra level of safety by precisely measuring the air velocity and continuously updating the proportional control signal to the heater. This avoids tripping the thermal cutouts for VAV applications, if the air filters are dirty or if there is an obstruction in the duct.

The Neptronic HEC universal controller considers only convection heat and differential temperature. It continuously updates the signal to the solid state relay. The result is an extremely precise control of heater output.

Features:

Inputs

- Analog: 0-10 VDC, 2-10 VDC or 4-20 mA.
- Pulsed: AC pulsed to ground, AC pulsed to 24 VAC or DC pulsed to ground.
- Pneumatic: modulating 0-15 PSI, direct or reverse action.
- Resistive NEP signal: from STS3 room thermostat, ITO3 setpoint controller + STC8-13 duct sensor or ITO3 setpoint controller + WS100 wall sensor.

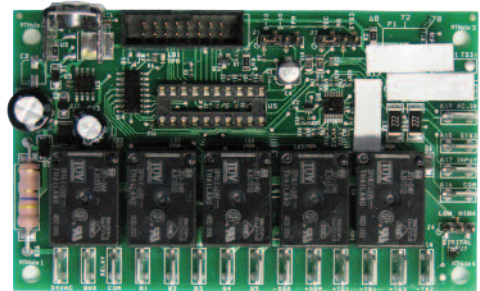

fig.3.17

Outputs

- TPM signal: 1-24 VDC for solid state relay.
- ON/OFF: Up to 4 step control for ON/OFF stages (standard), additional steps optional, Hybrid control - Sequential or Binary.
- Option: Fan relay for fan contact or pilot light contact.

Internal setpoint Option

Internal Setpoint option allows you to control the temperature setpoint with a potentiometer directly installed onto the HEC board. In this case, the electric heater will only be connected to a STR1 wall sensor or a STC8-13 duct sensor.

Patented EAS (Electronic Air Flow Sensors) US 7, 012, 223

- Accurate air flow readings without using air flow switches
- Lowers capacity if velocity is insufficient
- Operates as low as 100FPM (ideal for VAV applications)
- Additional heater element overheat protection
- Eliminates need to define air flow orientation

*Available for modulating open coil models under 40kW and less than 3ft x 3ft

Typical Wiring Diagrams

Three phase supply

ON/OFF electric signal - 2 stages

(Equipped with disconnect switch, stage fuses and airflow switch options)

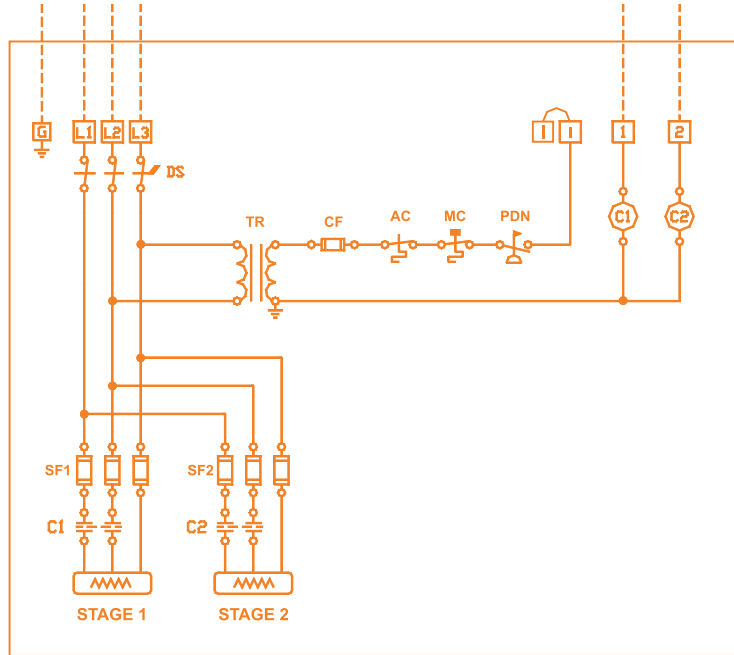

(for legend see next page)

fig.3.18

Three phase supply

Modulating (0-10VDC) electric signal - 3 stages

(Equipped with disconnect switch and stage fuses options).

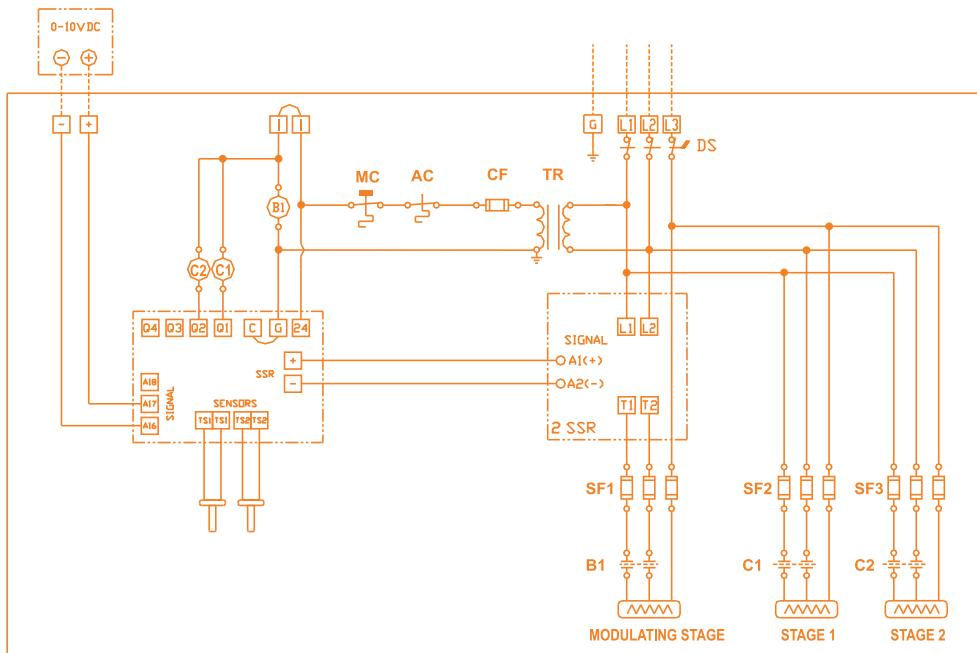

(for legend see next page)

fig.3.19

Single phase supply
ON/OFF Pneumatic signal - 2 stages
 (equipped with disconnect switch, stage fuses and airflow switch options)

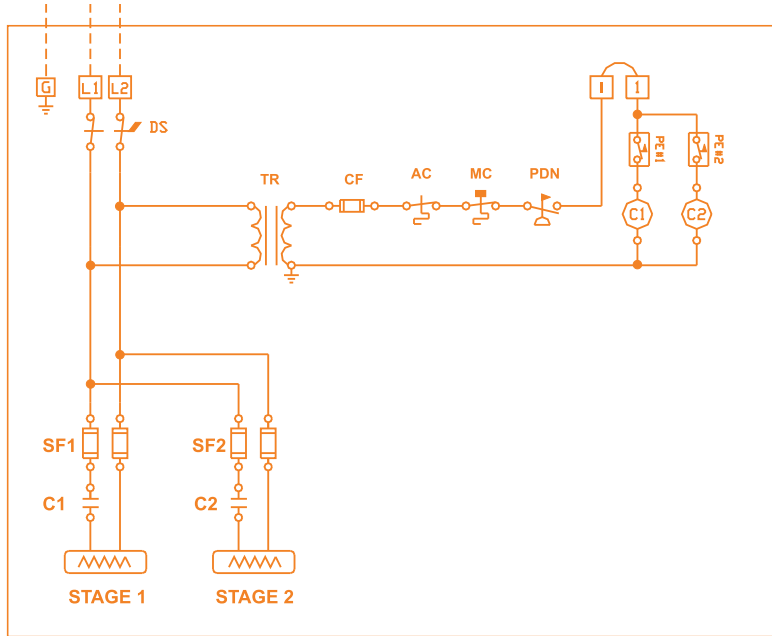

(for legend see next page)

fig.3.20



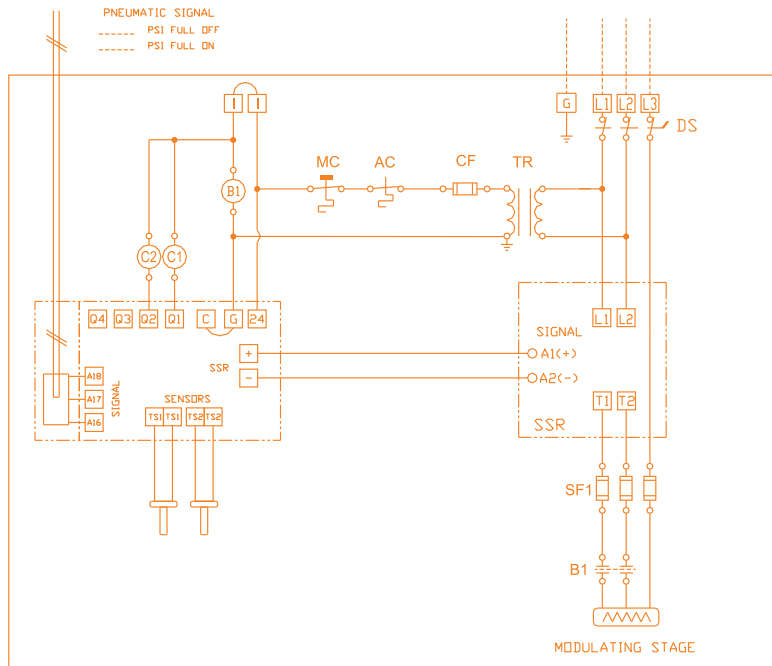



















Three phase supply
Modulating pneumatic signal - 3 stages
 (Equipped with disconnect switch and stage fuses options)



(for legend see next page)

fig.3.21

Legend

Components		Terminals	
Automatic Reset Thermal Cutout	AC 		Terminal Block Single phase
Manual Reset Thermal Cutout	MC 		Terminal Block 3 Phase
Airflow Switch	PDN 		Power Block
Disconnect Switch	DS 		Ground Terminal
Contact (N.O.) (normally open)			Interlock
Contact (N.C.) (normally closed)			Terminal Block (control)
Transformer	TR 		Solid State Relay Terminals (Input) by others
Contactor Coil			Solid State Relay Terminals (Output) by others
Back-up Contactor Coil			Control Circuit Supply
Fuse	F 		Pilot Light
Heating Element			
Pneumatic Electric Switch	PE#1 		
Modulating Pneumatic Controller			

THERMOSTATS AND SENSORS



Duct Mount Temperature Sensor - STC8-13

The Neptronic STC8-13 duct sensor transmits temperature of the air to be heated.

The required setpoint can be adjusted directly on the Neptronic HEC controller with the internal setpoint option or by using the Neptronic ITO3 setpoint controller or with a Neptronic TRO5404 thermostat. The control logic is integrated into the Neptronic HEC controller installed in the electric heater control panel.

When using STC8-13 + ITO3, the ITO3 can be installed on a wall or on the duct close to the STC8-13.

- High accuracy and stability
- Fast thermal response
- Epoxy encapsulated sensor
- Extended durability
- Resistor/Temperature Curve
 - “G” matched (STC8-11, 10K Ω)
 - “A” matched (STC8-13, 3.3 K Ω)

Operation:

The STC8-13 is installed directly onto the ventilation duct by inserting the tube with the temperature sensor into the duct, downstream of the electric heater. The two wires of the STC8-13 sensor are connected directly onto the ITO3 setpoint controller (or TRO5404 thermostat) which is then connected to the Neptronic HEC controller located in the electric heater control panel or directly to the Neptronic HEC controller if internal setpoint option has been chosen. Two 18AWG wires are required for any of these connections.



fig.4.1

Wall Mount Temperature Sensor- STR1

- Available with 10K Ω (STR1-11) or 3.3K Ω (STR1-13) thermistor
- High accuracy and stability
- Negative Temperature Coefficient (NTC)
- Compatible with Neptronic products



fig.4.2

VAV Wall Mount Controller- TRO24-EXT1

The TRO24-EXT1 is a combination controller and thermostat. The VAV Thermostat Controller is designed for simple and accurate control of any variable air volume box in a number of zone control configurations. Its field configurable algorithms enable versatile implementation of required control sequences.

Features:

- Configurable inputs and outputs
 - 4 TRIAC outputs (on/off, pulsed, or floating)
 - 2 analog outputs (0-10Vdc heat/cool)
 - 3 analog sensor inputs
- Precise temperature control with programmable PI function
- Selectable Fahrenheit or Celsius scale
- Extended setpoint range
- Manual night set back override
- Multi level lockable access menu and setpoint
- Selectable internal or external temperature sensor (10 K Ω)
- Changeover by contact or external temperature sensor
- Pressure sensor input with air flow program
- Selectable proportional control band and dead band



fig.4.3

Specifications:

Power supply: 22 to 26Vac 50/60Hz

Power consumption: 1VA

Setpoint range: -30°C to 90°C (-22°F to 194°F) with external sensor

External sensor range: -40°C to 100°C (-40°F to 212°F)

Proportional Band: 0.5°C to 5°C (1°F to 10°F) adjustable

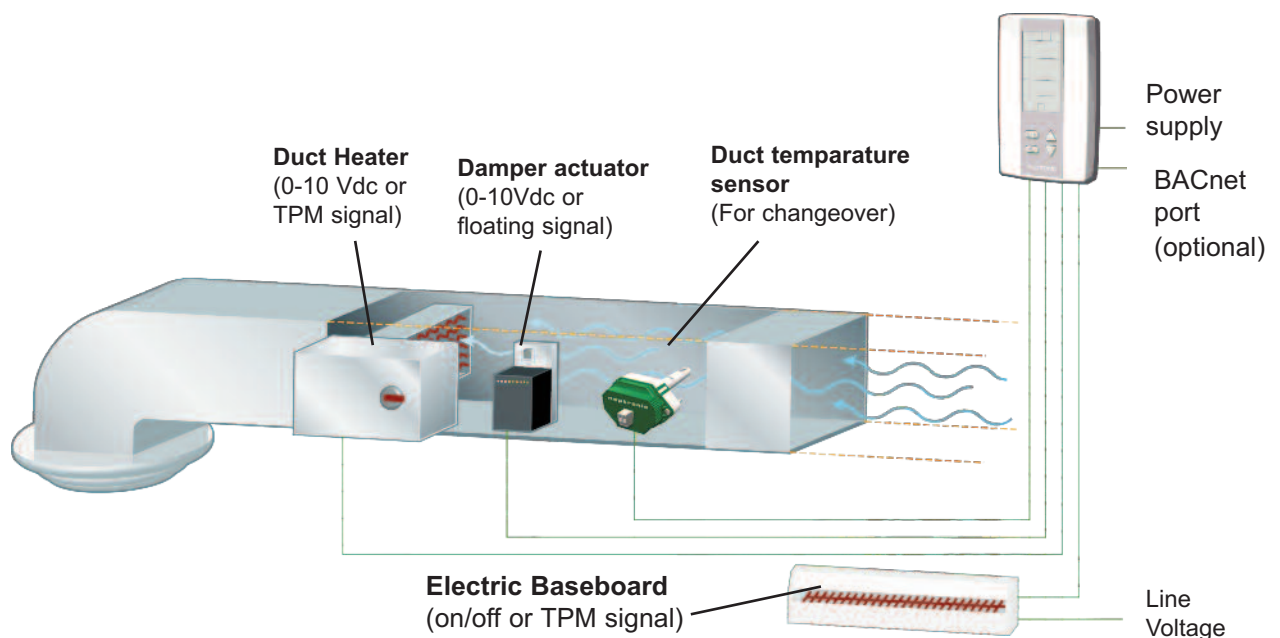

fig.4.4

VAV Wall Mount Controller- TRO5404

The Neptronic TRO5404 thermostat is for room temperature control applications. Two heating and two cooling output ramps are available. It includes 0-10 VDC proportional output signals for heating and cooling ramps and a TPM (time proportional modulation) output for heating. A NSB (night set back) input is available to use a different heat/cool setpoint for energy savings during unoccupied periods. An internal temperature sensor is standard with the TRO5404, however an external sensor (STC8-13) may be used.

Features:

Setpoint range: 10° to 35°C (50° to 95°F)

Power Supply: 22 to 26Vac

Proportional Band: 0.5°C to 4°C (1°F to 8°F) adjustable

Power consumption: 2VA

Output Signals:

- Proportional heating and cooling: 0-10VDC (2 heating and 2 cooling ramps)
- One TPM heating ramp: 0 or 22 VDC

NSB input (day/night adjustment)

Operation:

Proportional Mode:

The TRO5404 adjusts the 0-10VDC output signal proportionally to the difference between measured temperature and setpoint temperature.

The proportional band is adjustable between 0.5°C to 4°C (1°F to 8°F). With a 4°C (7°F) proportional band, a difference between the measured temperature and the setpoint temperature of 2°C (3.5°F) results in a 50% demand corresponding to 5VDC. The second proportional heating or cooling ramp may be used as a high demand signal.

TPM Mode (time proportional modulating) for Heating:

This mode allows the adjustment of a TPM period of 2 seconds proportional to the difference between measured temperature and setpoint temperature. The output voltage is a 24VDC pulse.

The proportional band is adjustable. With a 4°C (7°F) proportional band, a difference between the measured temperature and the setpoint temperature of 2°C (3.5°F) results in a 50% demand corresponding to 24VDC, half the time, i.e. every other second.

NSB Mode (day /night setting)

The NSB input is used to identify unoccupied periods, which use a separate cooling and heating setpoint for increased energy savings.



fig.4.5

Wall Mount Thermostat- STS3

The Nepronic STS3 wall mounted thermostat allows setpoint adjustment directly in the room where it is installed.

The control logic is integrated into the Nepronic HEC controller installed in the electric heater control panel.

This design makes the STS3 elegant, simple and affordable.

- Adjustable setpoint with mechanical lock
- Scale: Celsius or Fahrenheit
- Compatible with STC8-13 duct mounted temperature sensor in installations with Nepronic series duct heaters.
- Setpoint range: 14°C to 30°C (57°F to 86°F)

Operation:

The STS3 is installed directly on the wall. The two temperature sensor wires are connected to the Nepronic HEC controller located in the electric heater using two 18AWG wires.



fig.4.6

Wall Mount Controller for Make-Up Air- TMA54

The TMA54-EXT1 thermostat is designed for controlling an electric heater in a make-up air unit. This unit features a fully configurable Proportional-Integral-Derivative (PID) and can connect up to 5 outputs at one time.

Features:

- Configurable proportional-integral-derivative (PID)
- 2 Analog cooling outputs (0-10Vdc)
- 2 Analog heating outputs (0-10Vdc)
- TPM output (time proportional output)
- Selectable internal/external temperature sensor
- Manual Night Set Back (NSB) input
- NSB override
- Configurable NSB cooling and heating setpoints

Specifications:

Power supply: 22 to 26Vac 50/60Hz

Power consumption: 2VA

Setpoint range: 0° to 60°C (32° TO 140°F)

Internal temperature sensor: 0° to 50°C (32° to 122°F)

External temperature sensor: 10k Ω type 3 | Range: -40°C to +100°C (-40°F to +212°F)

Proportional band: 0.5° to 20° (1° to 40°F) adjustable



fig.4.7

This specification summary is designed to help you make a quick selection among the many available options.

1 - Selection of heating elements					
<input type="checkbox"/> Model C - Open coil elements <input type="checkbox"/> Grade C <input type="checkbox"/> Grade A		<input type="checkbox"/> Model T - Standard tubular elements <input type="checkbox"/> Incoloy 800 <input type="checkbox"/> Stainless Steel		<input type="checkbox"/> Model F - Finned tubular elements <input type="checkbox"/> Steel fins <input type="checkbox"/> Stainless Steel fins	
2 - Selection of duct type (Installation)					
<input type="checkbox"/> Type I - Slip-in		<input type="checkbox"/> Type F - Flanged <input type="checkbox"/> 1" (25.4mm) flange <input type="checkbox"/> 1.5" (38mm) flange		<input type="checkbox"/> Round collar option	
3 - Control panel details					
<input type="checkbox"/> Standard control panel Extends 1" (25.4mm) on top and bottom Left extension (if required)		<input type="checkbox"/> Special extension <input type="checkbox"/> Right extension <input type="checkbox"/> Bottom extension <input type="checkbox"/> Top extension <input type="checkbox"/> Centered extension		<input type="checkbox"/> Control panel flush with duct <input type="checkbox"/> Flush with top of duct <input type="checkbox"/> Flush with bottom of duct	
<input type="checkbox"/> Control panel on the bottom <input type="checkbox"/> Control panel on the top		<input type="checkbox"/> Insulated control panel 1" (25.4mm) thick insulation		<input type="checkbox"/> Remote control panel	
Degree of protection of control panel against external condition <input type="checkbox"/> NEMA Type 1 (IP10) <input type="checkbox"/> NEMA Type 12 (IP52) <input type="checkbox"/> NEMA Type 4 (IP56) <input type="checkbox"/> NEMA Type 4X (IP65)					
4 - Special electric heaters					
<input type="checkbox"/> Electric heater with cold section(s) <input type="checkbox"/> Cold section on control panel side; dimensions: _____ <input type="checkbox"/> Cold section opposite side of the control panel; dimensions: _____ <input type="checkbox"/> Cold section on top; dimensions: _____ <input type="checkbox"/> Cold section on bottom; dimensions: _____			<input type="checkbox"/> Process heater. Specify output temperature _____ (no thermal protection)		
5 - System information					
Air flow: _____ CFM <input type="checkbox"/> Horizontal <input type="checkbox"/> Vertical		Voltage: _____ VAC No. of phases: _____ Total power: _____ kW			
6 - Heating stage(s) details Input signal: <input type="checkbox"/> Pneumatic <input type="checkbox"/> Electric					
No. of stages	Control Signal	kW	No. of stages	Control Signal	kW
Stage 1	<input type="checkbox"/> ON/OFF <input type="checkbox"/> Modulating		Stage 3	<input type="checkbox"/> ON/OFF	
Stage 2	<input type="checkbox"/> ON/OFF		Stage 4	<input type="checkbox"/> ON/OFF	
7 - Control panel components			Options:		
Standard components:			Options:		
<input type="checkbox"/> Transformer and control fuse (TR) <input type="checkbox"/> 60 Hz <input type="checkbox"/> 50 Hz			<input type="checkbox"/> Control voltage provided by others <input type="checkbox"/> 24Vac <input type="checkbox"/> 120Vac (on-off only)		
<input type="checkbox"/> Disconnect switch by others <small>(Supplied when required by code)</small>			<input type="checkbox"/> Disconnect switch (door interlock) (DS) or <input type="checkbox"/> Toggle switch (TS)		
<input type="checkbox"/> No line or stage fuse <small>(Supplied when required by code)</small>			<input type="checkbox"/> Line fuses (LF) and/or <input type="checkbox"/> Stage fuses (SF)		
<input type="checkbox"/> Magnetic contactor (CA) <input type="checkbox"/> Full break			<input type="checkbox"/> Mercury contactor (CM) <input type="checkbox"/> Thermal relay (RT)		<input type="checkbox"/> Full break
<input type="checkbox"/> Silent relay (CS)			<input type="checkbox"/> Manual reset thermal cutout (MC) <small>(Supplied when required by code)</small>		
<input type="checkbox"/> Manual reset thermal cutout (MC)			<input type="checkbox"/> Airflow switch, fixed (PDN) or <input type="checkbox"/> adjustable (PDA)		
<i>For modulating electric heaters:</i> <input type="checkbox"/> HEC Electronic controller (HEC) <input type="checkbox"/> Solid state relay (SSR)			<input type="checkbox"/> Fan relay (FR) <input type="checkbox"/> Starter motor for fan, Power : ____ HP		
<input type="checkbox"/> No pilot lights			<input type="checkbox"/> Auxiliary switches (normally open & normally closed) (AUX) Qty : <input type="checkbox"/> 1 per contactor or <input type="checkbox"/> 2 per contactor		
			<input type="checkbox"/> Pilot lights <input type="checkbox"/> Line Power (LP) <input type="checkbox"/> Heating ON (LH) <input type="checkbox"/> No airflow (LN) <input type="checkbox"/> Stage ON (LS) <input type="checkbox"/> Overheat (LO)		
8 - Thermostats and Sensors					
<input type="checkbox"/> STS3		<input type="checkbox"/> TRO5404		<input type="checkbox"/> TRO24-EXT1	
				<input type="checkbox"/> TMA54	
<input type="checkbox"/> STC8-13 + ITO3 - Duct sensor and room set point controller					
<input type="checkbox"/> STC8-13 + TRO5404 - Duct sensor and room modulating thermostat			<input type="checkbox"/> STR1		
<input type="checkbox"/> STC8-13 + HEC/ISP - Duct sensor and Internal set point controller					

See overleaf to select reference number of required electric heater.

NOMENCLATURE

D F C F 0 1 H

C Open coil elements
T Tubular elements
F Finned tubular elements

I Slip-In
F Flanged
 Round collar option

0 No protective screen to the left of the control panel
1 Protective screen to the left of control panel

0 No protective screen to the right of control panel
1 Protective screen to the right of control panel

H Horizontal airflow
V Vertical airflow

Example:

DF C I 1 1 H

Open coil elements, slip-in type, screen to the left and right of control panel, horizontal installation.

DF F F 0 0 V:

Finned tubular elements, flanged type, no screens, vertical installation.

Electrical Options				Mechanical Options			
FC	Full Break Contactor	PDN	Pressure Differential Switch - Non adjustable	PSO	Pneumatic/Electric Switch Normally Open	CBT	Control box on Top
RT	Thermal Relay	AUX	Auxiliary switch (specify quantity max. 2)	PSC	Pneumatic/Electric Switch Normally Closed	CBB	Control box on Bottom
CA	Magnetic Contactor	PDA	Pressure Differential Switch - Adjustable	PCD	Pneumatic/Electric Controller Direct Acting	BCC	Control Box Centered
CS	Silent Relay	HEC	Neptronic Electronic Controller	PCR	Pneumatic/Electric Controller Reverse Acting	BBE	Control box with top extension
CM	Mercury Contactor	HEC/ISP	Neptronic HEC Controller with Internal setpoint	CGA	Open Coil Grade A	BCE	Control box with Bottom extension
LF	Load Fuses	EAS	Electronic Airflow Sensor (HEC required)	EF	Extended Flange - 1.5" (38mm)	BLE	Control box with Left extension
SF	Stage Fuses	SSR	Solid State Relay	PH	Process Heater	BRE	Control box with Right extension
DS	Disconnect Switch with Door Interlock	LP	Pilot Light - Power	N12	Control Panel - NEMA 12 (IP52)	VAV	Control box adapted to VAV application
TS	Toggle Switch	LH	Pilot Light - Heating	N4	Control Panel - NEMA 4 (IP56)	CC	Cold spot on Control box side
AC	Automatic Thermal cutout	LN	Pilot Light - No Airflow	N4X	Control Panel - NEMA 4X (IP65)	CE	Cold spot on End side (opposite of Control box)
MC	Manual Thermal cutout	LS	Pilot Light - Stage On	RP	Remote Panel	CT	Cold spot on Top
TR	Transformer	LO	Pilot Light - Overheat	SB	Stainless Control box	CB	Cold spot on Bottom
TF	Transformer Fuse (primary)	FR	Fan Relay	SBF	Stainless Control box & Frame	BFT	Control box Flush Top
CF	Control Fuse	SMA	Starter Motor for Fan Automatic	IB	Insulated Control box	BFB	Control box Flush Bottom

Please contact factory for special options

Specification: Open Coil Element Heater

Supply as described below and/or on the drawings, CSA approved electric heaters according to CSA standard C22.2 No. 155 and UL 1996, as manufactured by Neptronic.

Mechanical Construction

Neptronic electric heaters shall be manufactured using galvanized steel of appropriate gauge and will provide proper rigidity and resistance to corrosion.

Electric heaters will be manufactured and approved for zero clearance for all combustible materials.

Heating Elements (Open Coil)

Heating elements will be manufactured from a grade C nickel chrome alloy (NiCr60).

Modulating Heaters

Neptronic modulating electric heaters will be supplied with an electronic sensor on each side of the heater to measure the temperature and the airflow, and a Neptronic HEC controller to adjust the output temperature in accordance with the measured parameters. The Neptronic HEC controller will stop the electric heater when there is no airflow.

Electrical Construction

Electric heaters will be supplied with a control panel with electric components adapted to the required voltage and current of the system.

The control panel will be manufactured for indoor conditions and will provide safety features against accidental contact with internal components (Nema type 1) (IP10).

The control panel will include a removable, hinged door to provide easy access.

The connection terminals will be clearly identified, and a corresponding wiring diagram will be affixed to the control panel.

The following standard components will be installed:

- Transformer with secondary fuse
- Magnetic contactor
- Automatic thermal cutout
- Manual thermal cutout (when required by code)
- Airflow switch
- Solid state relay (modulating control)

Additional components are optional, see list of options.

Safety

Electric heaters shall be supplied with the appropriate thermal cutout to protect the installations and the users against the risk of overheating.

Inspections and tests will be performed before delivery according to safety and quality standards.

Protective screens will be installed upon request, see list of options.

System Conditions

Electric heater operation shall not be affected by airflow direction and heaters may be installed in either vertical or horizontal ventilation ducts. To ensure that the electric components are correctly placed, please specify the direction of airflow.

Modulating electric heater operation shall not be affected by the airflow direction. The Neptronic HEC controller will automatically recognize the direction of airflow and will operate accordingly.

The mechanical dimensions and electrical requirements as well as the airflow will be as indicated on the heater schedule.

Approvals

Mechanical drawings and wiring diagrams shall be submitted to the Consulting Engineer for approval prior to production.

List of Options

Mechanical Construction

Compulsory option, choose one of the three options:

- Slip-in electric heater
- Flanged electric heater
- Round collar electric heater

If one of the following options is selected, remove the corresponding standard description:

- Heating section (frame) in 304 stainless steel

Open Coil Elements

If one of the following options is selected, remove the corresponding standard description:

- Open coil elements in grade A (NiCr80) Nickel Chrome alloy, no traces of iron

Electrical Construction

If one of the following options is selected, remove the corresponding standard description:

- 304 stainless steel control panel
- Remote control panel
- Nema12 (IP52) Control panel (protection against dust)
- Nema4 (IP56) Control panel (protection against foul weather)
- Nema4X (IP56) Control panel (protection against foul weather and corrosion)
- No transformer-control voltage provided by others
- No contactor-control components provided by others
- Mercury Contactor
- Disconnect switch -no door interlock
- Disconnect switch with door interlock
- Load fuses HRC form 1
- Stage fuses HRC form 1
- Manual reset thermal cutout
- Neptronic HEC controller, assures precise modulation for heating demand and provides protection against overheating if there is a decrease in airflow.
- Power supply pilot light
- Stage pilot light
- Airflow pilot light
- Overheat pilot light

Heater Protective Screens

Optional:

- 1 protective screen to the left of control panel.
- 1 protective screen to the right of control panel.
- 1 protective screen to the left and one to the right of control panel.

Special Construction

Neptronic electric heaters may be constructed to adapt to particular conditions. Special construction will be available upon request according to the many options described in the catalogue and on the options summary sheet.

Specification: Tubular Element Heater

Supply as described below and/or on the drawings, CSA approved electric heaters according to CSA standard C22.2 No. 155 and UL 1996, as manufactured by NEP (Neptronic).

Mechanical Construction

Neptronic electric heaters shall be manufactured using galvanized steel of appropriate gauge and will provide proper rigidity and resistance to corrosion.

Electric heaters will be manufactured and approved for zero clearance for all combustible materials.

Heating Elements (Standard Tubular)

Heating elements will be standard tubular type, made of an Incoloy 800 (Nickel alloy) tube with a diameter of 3/8" (9.5mm) containing a heating coil in magnesium oxide powder.

Modulating Heaters

Neptronic modulating electric heaters will be supplied with an electronic sensor on each side of the heater to measure the temperature and the airflow, and a Neptronic HEC controller to adjust the output temperature in accordance with the measured parameters. The Neptronic HEC controller will stop the electric heater when there is no airflow.

Electrical Construction

Electric heaters will be supplied with a control panel with electric components adapted to the required voltage and current of the system.

The control panel will be manufactured for indoor conditions and will provide safety features against accidental contact with internal components (Nema type 1) (IP10).

The control panel will include a removable, hinged door to provide easy access.

The connection terminals will be clearly identified, and a corresponding wiring diagram will be affixed to the control panel.

The following standard components will be installed:

- Transformer with secondary fuse
- Magnetic contactor
- Automatic thermal cutout
- Manual thermal cutout (when required by code)
- Airflow switch
- Solid state relay (modulating control)

Additional components are optional, see list of options.

Safety

Electric heaters shall be supplied with the appropriate thermal cutout to protect the installations and the users against the risk of overheating.

Inspections and tests will be performed before delivery according to safety and quality standards.

Protective screens will be installed upon request, see list of options.

System Conditions

Electric heater operation shall not be affected by airflow direction and heaters may be installed in either vertical or horizontal ventilation ducts. To ensure that the electric components are correctly placed, please specify the direction of airflow.

Modulating electric heater operation shall not be affected by the airflow direction. The Neptronic HEC controller will automatically recognize the direction of airflow and will operate accordingly.

The mechanical dimensions and electrical requirements as well as the airflow will be as indicated on the heater schedule.

Approvals

Mechanical drawings and wiring diagrams shall be submitted to the Consulting Engineer for approval prior to production.

List of Options

Mechanical Construction

Compulsory option, choose one of the three options:

- Slip-in electric heater
- Flanged electric heater
- Round collar electric heater

If one of the following options is selected, remove the corresponding standard description:

- Heating section (frame) in 304 stainless steel

Heating Elements (Finned Tubular)

If one of the following options is selected, remove the corresponding standard description:

- Heating element shall be finned tubular type, made of an Incoloy 800 (Nickel alloy) tube with a diameter of .375" (9.5mm) containing a heating coil in magnesium oxide powder.

Electrical Construction

If one of the following options is selected, remove the corresponding standard description:

- 304 stainless steel control panel
- Remote control panel
- Nema12 (IP52) Control panel (protection against dust)
- Nema4 (IP56) Control panel (protection against foul weather)
- Nema4X (IP56) Control panel (protection against foul weather and corrosion)
- No transformer-control voltage provided by others
- No contactor-control components provided by others
- Mercury Contactor
- Disconnect switch -no door interlock
- Disconnect switch with door interlock
- Load fuses HRC form 1
- Stage fuses HRC form 1
- Manual reset thermal cutout
- Nepronic HEC controller, assures precise modulation for heating demand and provides protection against overheating if there is a decrease in airflow.
- Power supply pilot light
- Stage pilot light
- Airflow pilot light
- Overheat pilot light

Heater Protective Screens

Optional:

- 1 protective screen to the left of control panel.
- 1 protective screen to the right of control panel.
- 1 protective screen to the left and one to the right of control panel.

Special Construction

Nepronic electric heaters may be constructed to adapt to particular conditions. Special construction will be available upon request according to the many options described in the catalogue and on the options summary sheet.

Formulas

Power or electric heater capacity

Imperial

$$kW = \frac{CFM \times (T^{\circ}2 - T^{\circ}1) \times 1.08}{3413}$$

*kW : Power in kW
CFM : Air volume in Cubic Feet per Minute
T[°]2 : Temperature of air leaving heater in °F
T[°]1 : Temperature of air entering heater in °F*

Metric

$$P = \frac{Q \times (T^{\circ}2 - T^{\circ}1) \times 1,21}{3600}$$

*P : Power in kW
Q : Air volume in m³/hour
T[°]2: Temperature of air leaving heater in °C
T[°]1: Temperature of air entering heater in °C*

Temperature differential $\Delta T = T^{\circ}2 - T^{\circ}1$

Imperial

$$\Delta T = \frac{kW \times 3413}{CFM \times 1.08}$$

Metric

$$\Delta T = \frac{P \times 3600}{Q \times 1,21}$$

KW per square foot

Imperial

$$kW / ft^2 = \frac{kW}{S}$$

*kW : Power in kW
S : Surface area in square feet*

Metric

$$kW / m^2 = \frac{P}{S}$$

*P : Power in kW
S : Surface area in m²*

Duct area

Imperial

$$S = \frac{W \times H}{144}$$

*S : Surface area in square feet
W : Duct width in inches
H : Duct Height in inches*

Metric

$$S = W \times H$$

*S : Surface area in m²
W :Duct width in meter
H : Duct height in meter*

Electric power

Single phase

$$P = V \times I \quad \text{ou} \quad P = \frac{V^2}{R}$$

3 phase

$$P = V \times I \times 1.732 \quad P = \frac{V^2}{R} \times 1.732$$

*P : Power in Watts
V : Voltage in Volts
R : Resistance in Ω (Ohm)
I : Current in Amps*

Line current

Single phase

$$I = \frac{P}{V}$$

3 phase

$$I = \frac{P}{V \times 1.732}$$

Conversions

°F to °C

$$^{\circ}C = \frac{(^{\circ}F - 32)}{1.8}$$

°C to °F

$$^{\circ}F = (1.8 \times ^{\circ}C) + 32$$

BTU to kW

$$1 \text{ kW} = 3413 \text{ BTU/hre}$$

kW to BTU

$$1 \text{ BTU/hre} = 0.29307 \times 10^{-3} \text{ kW}$$

mm to inches

$$1 \text{ in} = 25.4 \text{ mm}$$

Inches to mm

$$1 \text{ mm} = 0.03937 \text{ in}$$

CFM to FPM

$$1 \text{ FPM} = \frac{1 \text{ CFM}}{S}$$

FPM to CFM

$$1 \text{ CFM} = 1 \text{ FPM} \times S$$

S : Surface area in square feet

NOTES

These products are subject to the terms and conditions described at:
<http://www.neptronic.com/Sales-Conditions.aspx>